



FEATURES

- Universal 85 - 277VAC or 120 - 390VDC Input voltage
- Operating ambient temperature range: -40°C to +85°C, 60 °C @ 100% load without derating
- Efficiency up to 95%
- Active PFC, PF>0.97
- DC OK function
- Double-sided conformal coating, salt-spray proof, explosion-proof
- Operating altitude up to 5000m
- OVC III (Safety according to EN61010)
- Input under-voltage protection
- Output short circuit, over-current, over-voltage, over-temperature protection
- Safety according to ATEX, IECEx increased safety type explosion-proof certification
- 5 years warranty
- Safety according to ANSI/ISA 71.04-2013 G3
- Safety according to IEC/EN/UL62368, UL61010, UL508

LIMF480-23Bxx is Mornsun explosion-proof Din-rail power supply featuring with high performance, high reliability, high efficiency. Up to 95% efficiency can greatly improve power supply reliability and service life. It can work at ambient temperature of -40°C to +85°C without adding a fan for heat dissipation. With good EMC performance and compliant with international standards of IEC/EN/UL62368, UL61010, UL508 for EMC and safety. They are widely used in wind power industry, DCS, industrial control equipment, machine control, LED, 5G communication and other fields.

Selection Guide

Certification	Part No.*	Output Power (W)	Nominal Output Voltage and Current (Vo/Io)	Output Voltage Adjustable Range (V)	Efficiency at 230VAC (%) Typ.	Max. Capacitive Load (μF)
--	LIMF480-23B24	480	24V/20A	24-28	95.0	100000
	LIMF480-23B48		48V/10A	48-56	95.5	25000

Note: * When the output voltage rises, the total power of the product should not exceed the rated power;

Input Specifications

Item	Operating Conditions		Min.	Typ.	Max.	Unit
Input Voltage Range	Rated input (Certified voltage)		100	--	240	VAC
	AC input		85	--	277	
	DC input		120	--	390	VDC
Maximum Input Voltage	Lasts for 2h without damage		--	--	305	VAC
Input Voltage Frequency			47	--	63	Hz
Input Switching Voltage			60	--	70	VAC
Input Turn-off Voltage			75	--	85	
Input Current	115VAC		--	--	5	A
	230VAC		--	--	2.5	
Inrush Current	115VAC		--	--	15	A ² s
	230VAC		--	--	35	
Inrush Current Integral (I ² t)	115VAC		--	0.2	--	
	230VAC		--	0.8	--	

Power Factor	Rated load	115VAC	0.99	--	--	--
		230VAC	0.97	--	--	
THD	230VAC, rated load		--	2	--	%
Start-up Delay Time	115VAC/230VAC, rated load		--	400	--	ms
Rise Time			--	25	--	
Input Fuse	Built-in fuse		--	8	--	A
DC OK Signal	Resistive load		30VDC/1A Max.			
Hot Plug			Unavailable			

Output Specifications

Item	Operating Conditions		Min.	Typ.	Max.	Unit
Output Voltage Accuracy	Full load range		--	±1.0	--	%
Line Regulation	Rated load		--	±0.25	--	
Load Regulation	0% - 100% load		--	±0.5	--	
Power Consumption*	230VAC, rated load	24V	--	24	--	W
		48V	--	21.6	--	
Ripple & Noise*	20MHz bandwidth, peak-to-peak value	24V	--	--	100	mV
		48V	--	--	150	
Hold-up Time	115VAC/230VAC		--	22	--	ms
DC OK Relay	Operation voltage	24V	--	21.6	--	V
		48V	--	43.2	--	
	Release voltage	24V	--	19.2	--	
		48V	--	38.4	--	
Short Circuit Protection	Constant current		115	125	140	%
Over-current Protection	115VAC/230VAC		110% - 140% Io (typ. 125%Io, constant current, self-recover)			
Over-voltage Protection	24V		<32VDC (Output-off or clamping, self-recover)			
	48V		<60VDC (Output-off or clamping, self-recover)			
Over-temperature Protection*	230VAC, rated load	Over-temperature protection start	--	--	95	°C
		Over-temperature protection release	60	--	--	

Note:
 1.* Power consumption curve, over-current protection mode and short circuit protection mode see product characteristic curve;
 2.* The "Tip and barrel method" is used for ripple and noise test, output parallel 47uF electrolytic capacitor and 0.1uF ceramic capacitor, please refer to Enclosed Switching Power Supply Application Notes for specific information;
 3.* Over-temperature protection: Put the product into a high temperature box. After the ambient temperature stabilizes, increase the temperature slightly (3°C to 5°C), and the load remains unchanged. After the product reaches thermal equilibrium, increase the temperature until the product triggers over-temperature protection.

General Specifications

Item	Operating Conditions		Min.	Typ.	Max.	Unit
Isolation Test*	Input - ⊕	Electric strength test for 1min., leakage current <5mA	2500	--	--	VAC
	Input - output	Electric strength test for 1min., leakage current <10mA	4000	--	--	
	Output - ⊕	Electric strength test for 1min., leakage current <5mA	1500	--	--	
Insulation Resistance	Input - ⊕	Environment temperature: 25±5°C Relative humidity: <95%, non-condensing Test voltage: 500VDC	500	--	--	MΩ
	Input - output			--	--	
	Output - ⊕			--	--	
Operating Temperature			-40	--	+85	°C
Storage Temperature			-40	--	+85	
Operating Humidity	Non-condensing		10	--	95	%RH
Storage Humidity			20	--	90	

Switching Frequency*	PFC	58	--	77	kHz
	DC-DC	40	--	130	
Power Derating	Operating temperature derating @AC input	-40°C to -30°C	2	--	% / °C
		-30°C to +60°C	0	--	
		+60°C to +80°C	3.75	--	
	Operating temperature derating @DC input	-40°C to -30°C	2	--	
		-30°C to +60°C	0	--	
		+60°C to +80°C	2	--	
	Input voltage derating	85VAC - 100VAC	1	--	% / VAC
		100VAC - 277VAC	0	--	
120VDC - 140VDC		1	--	% / VDC	
140VDC - 390VDC		0	--		
Leakage Current	240VAC	<1.5mA			
Safety Standard	Design refer to IEC/EN/UL62368-1, UL61010-1, UL508				
Safety Class	CLASS I, ANSI/ISA71.04-2013				
MTBF	MIL-HDBK-217F@25°C	>702,000h			
	MIL-HDBK-217F@40°C	>504,000h			
Warranty	Ambient temperature: <40°C	5 years			
High and Low Voltage Crossing	Test with Mornsun P/N: LUPS20-24F-N-UNT	NB/T 31111-2017			
<p>Note: 1.* ①Remove the screw at the mark Ⓢ when the product is subjected to withstand voltage test; ② The gas discharge tube built into the device effectively protects the power supply against damage by asymmetric disturbance variables (eg EN 61000-4-5). Each power supply continuous withstand voltage test will cause extremely high load to the power supply. Therefore, unnecessary loading or damage to the power supply due to excessive test voltage should be avoided. If necessary, disconnect the gas discharge tube built into the device to use a higher test voltage. After successful completion of the test, reconnect the gas discharge tube. Please refer to the "LIMF480-23Bxx Installation and Application Manual" for specific operation methods;</p> <p>2. * The power supply has two converters with two different switching frequencies.</p>					

Environmental Characteristics

Item	Operating Conditions	Standard
High and Low Temperature Working	+85°C, -40°C	GB2423.1, IEC60068-2-1
Sinusoidal Vibration	10 - 500Hz, 2g, three directions of X, Y, Z axis	GB2423.10, IEC60068-2-6
Salt Mist	+35°C, 5%NaCl, 48h	GB2423.17, IEC60068-2-11
Alternating Hot and Humid	+25°C, 95%RH - +60°C, 95%RH	GB2423.4, IEC60068-2-30
Low Temperature Storage	-40°C	GB2423.1, IEC60068-2-1
High Temperature Storage	+85°C	GB2423.2, IEC60068-2-2
High Temperature Aging	+60°C	GB2423.2, IEC60068-2-2
Normal Temperature Aging	+25°C	GB2423.1, IEC60068-2-1
Temperature Shock	-40°C to +85°C	GB2423.22, IEC60068-2-14
Temperature Cycle	-25°C to +60°C	GB2423.22, IEC60068-2-14
Hot and Humid	+85°C, 85%RH	GB2423.50, IEC60068-2-67
High Temperature Elevation	+60°C, 54KPa	GB2423.26, IEC60068-2-41
Low Temperature Elevation	-25°C, 54KPa	GB2423.25, IEC60068-2-40
Constant Humid and Hot	+40°C, 95%RH	GB2423.3, IEC60068-2-78
Random Vibration	5 - 10Hz, ASD 0.3 - 10g ² /Hz, three directions of X, Y, Z axis	GB/T 4798.2-2008, IEC60721-3-2
Sinusoidal Vibration Response	10 - 150Hz, 1g, three directions of X, Y, Z axis	GB/T 11287-2000, IEC60255-21-1
Sinusoidal Vibration Endurance Test		
Sinusoidal Impulse Response		
Sinusoidal Impact Endurance Test	15g, pulse duration 11ms, three times in each direction of X, Y, Z axis	GB/T 114537-1993, IEC60255-21-2
Packaging Drop	1m, one corner, three edges and six sides	GB2423.8, IEC68-2-32

Mechanical Specifications

Case Material	Metal (AL5052, SUS304)
Dimensions	124.0mm x 55.0mm x 127.0mm
Weight	985g (Typ.)
Cooling Method	Free air convection

Electromagnetic Compatibility (EMC)*

EMC	Item	Standard	Range	Criteria	
Emissions	CE (Input port)	CISPR32 EN55032	150K - 30MHz	CLASS B	
	CE (Output port)	CISPR32 EN55032	150K - 30MHz	CLASS A	
	RE	CISPR32 EN55032	30MHz - 2GHz	CLASS B	
	Harmonic current	IEC/EN61000-3-2		CLASS A and CLASS D	
	Voltage flicker	EN61000-3-3		Fulfilled	
Immunity	ESD	IEC/EN61000-4-2	Contact ±8KV/Air ±15KV	perf. Criteria A	
	RS	IEC/EN61000-4-3	20V/m		
	EFT	IEC/EN61000-4-4 (Input port)	±4KV		
		IEC/EN61000-4-4 (Output port)	±2kv		
	Surge	IEC/EN61000-4-5 (Input port)	L to N ±3KV/L or N to PE ±6KV		
		IEC/EN61000-4-5 (Output port)	line to line ±1KV/line to ground ±2KV		
	CS	IEC/EN61000-4-6	0.15 - 80MHz 20Vr.m.s		
	AC power port harmonics	IEC61000-4-13	CLASS 3		
	Harmonic and network signal				
	Low frequency immunity				
	PFMF	IEC/EN61000-4-8	30A/m		
	Voltage dips, short interruptions and voltage variations immunity	IEC/EN61000-4-11	0% of 100Vac, 0Vac, 20ms		perf. Criteria A
			40% of 100Vac, 40Vac, 200ms		perf. Criteria C
70% of 100Vac, 70Vac, 500ms			perf. Criteria A		
0% of 200Vac, 0Vac, 20ms			perf. Criteria A		
40% of 200Vac, 80Vac, 200ms			perf. Criteria A		
70% of 200Vac, 140Vac, 500ms			perf. Criteria A		
Voltage interruption	IEC/EN61000-4-11	0% of 200Vac, 0Vac, 5000ms	perf. Criteria C		

Note:* perf. Criteria:

A: The equipment shall continue to operate as intended without operator intervention;

B: After the test, the equipment shall continue to operate as intended without operator intervention;

C: Loss of function is allowed, provided the function is self-recoverable, or can be restored by the operation of the controls by the user in accordance with the manufacturer's instructions.

Product Characteristic Curve

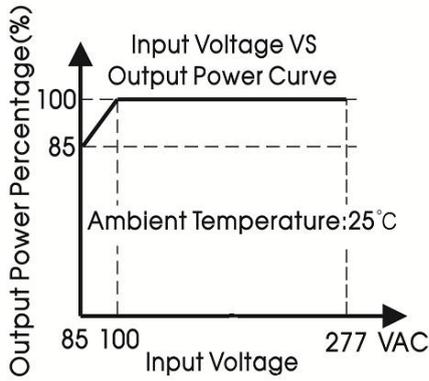

Figure 1

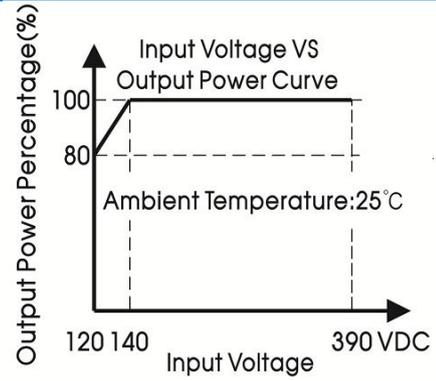

Figure 2

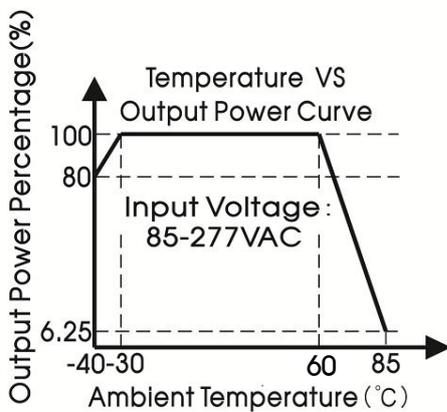

Figure 3

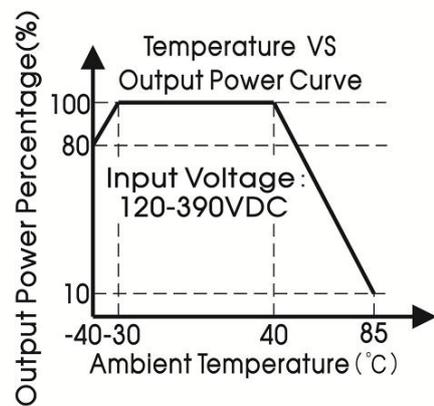

Figure 4

Over-current/ Short circuit protection curve (Typ.)

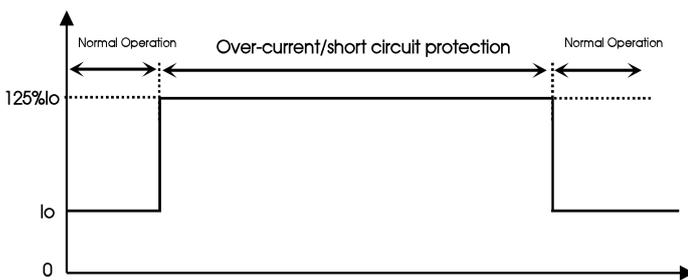

Figure 5

DC OK behavior curve (Typ.)

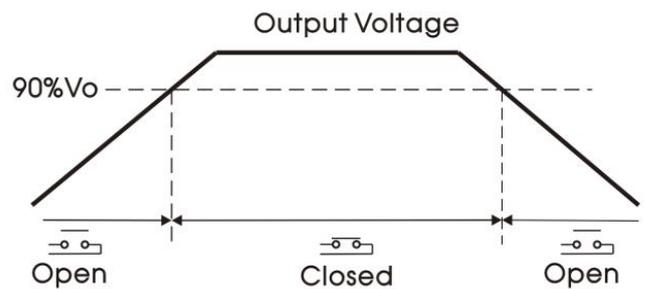

Figure 6

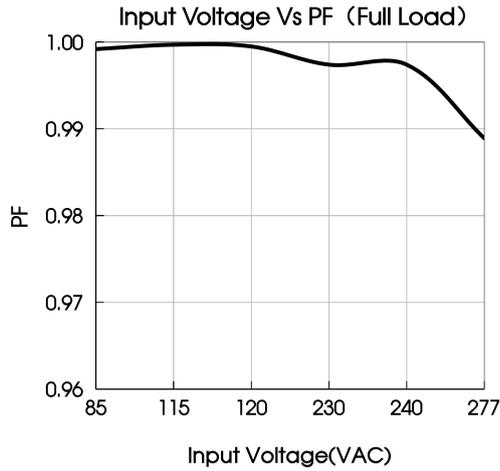

Figure 7

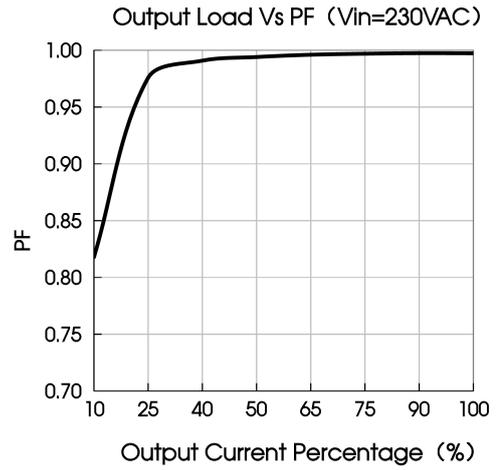

Figure 8

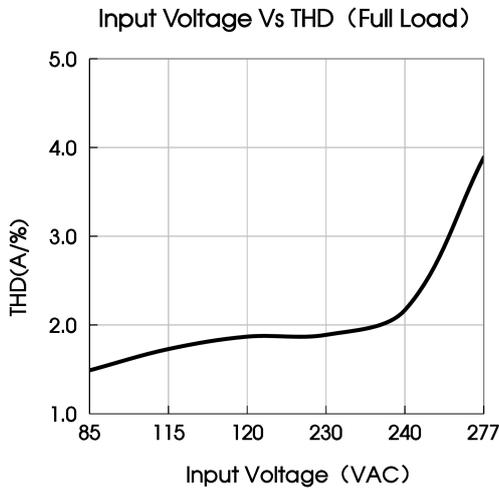

Figure 9

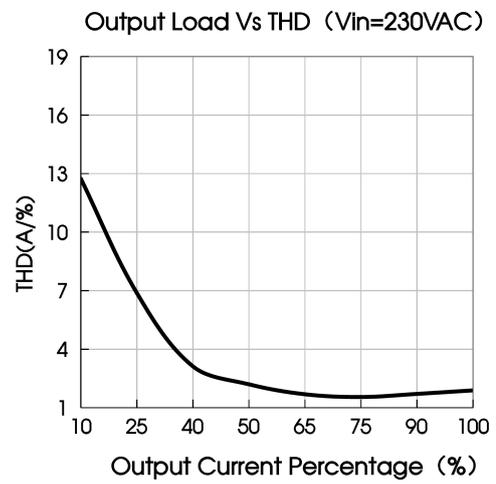

Figure 10

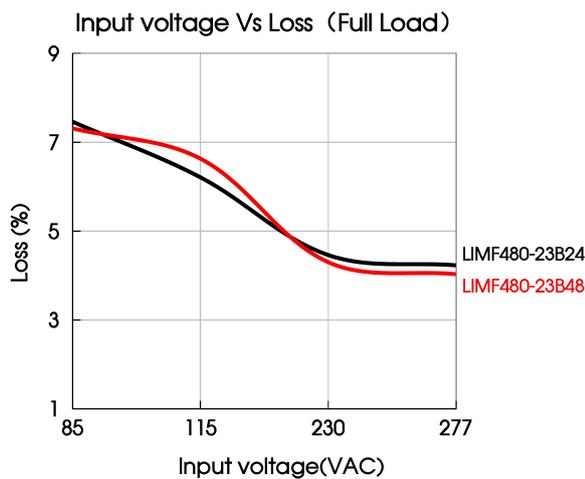

Figure 11

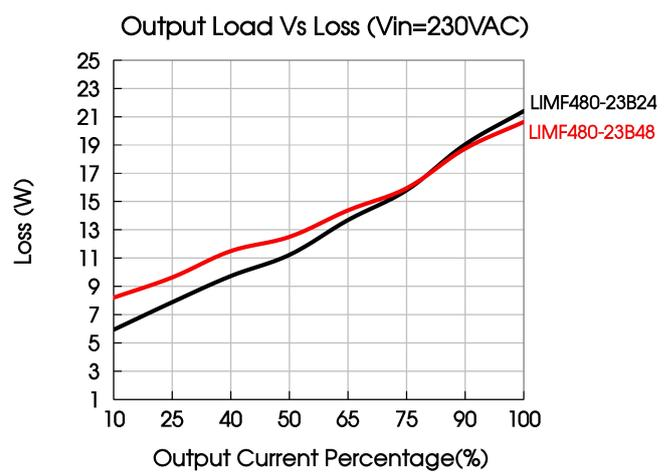

Figure 12

Note: 1. All curves are for 24V output, measured at input 230VAC, 50Hz, output I_o , ambient temperature 25°C, unless otherwise stated;
2. With an AC input voltage between 85-100VAC and a DC input between 120-140VDC the output power must be derated as per the temperature derating curves;
3. This product is suitable for applications using natural air cooling; for applications in closed environment please consult Mornsun FAE.

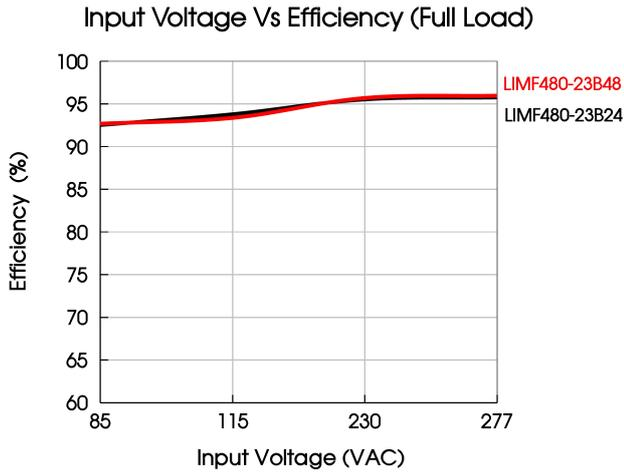

Figure 13

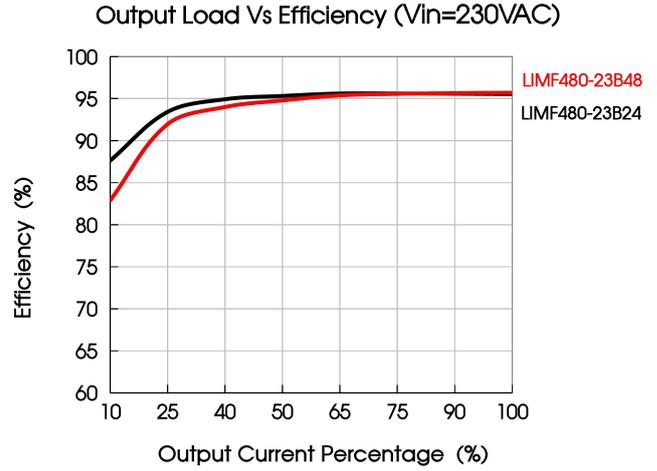
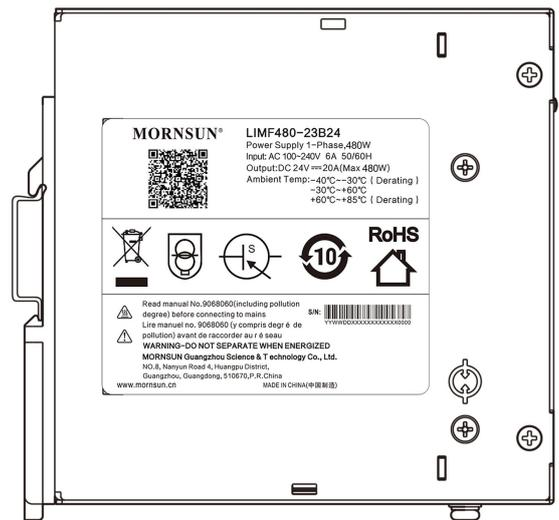
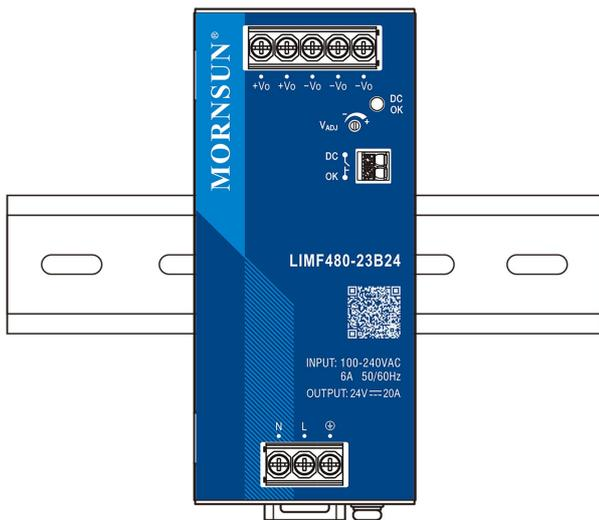

Figure 14

Installation Diagram



Note: Keep the following installation clearances: 20mm on the top, 20mm on the bottom, 5mm on the left and right sides are recommended when the device is loaded permanently with more than 50% of the rated power. Increase this clearance to 15mm in case the adjacent device is a heat source (e.g. another power supply).

Materials required in the installation

1	Product	1 PC
2	Phillips screwdriver Slotted screwdriver	1 PC
3	TS35/7.5 or TS35/15	1 PC
4	16-10AWG wire	/ PCS
	The content is for reference only. Regarding the actual wire diameter and tightening torque, refer to the dimensional drawing.	

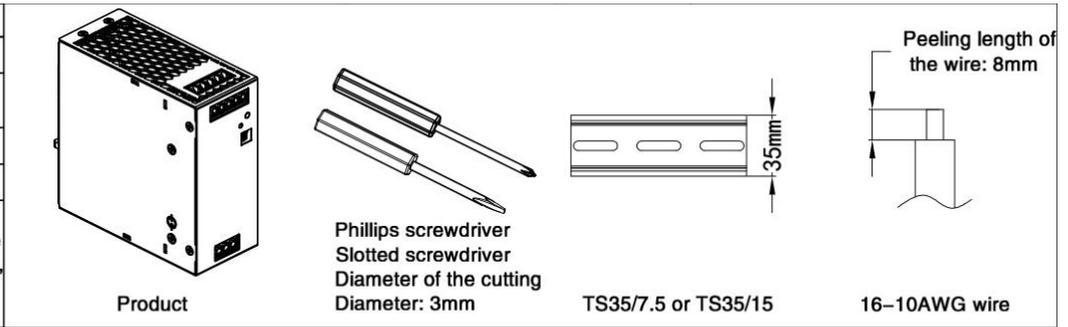

Installation steps ①-②

①Clamp the buckle of the product into the TS35 DIN rail.

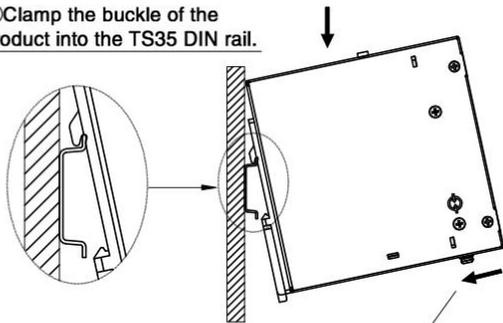

②Push the product vertically towards the TS35 DIN rail until hearing the sound of the buckle snapping into it.

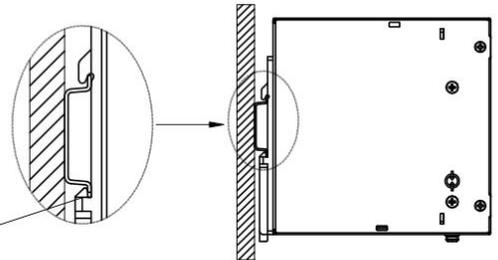

Disassembly steps ③-④

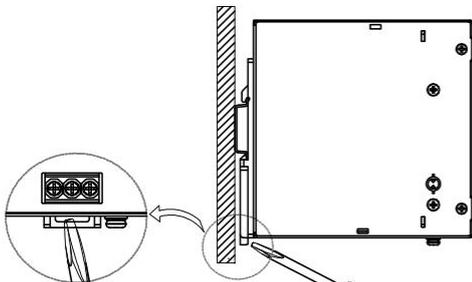

③After inserting the Slotted screwdriver into the square groove at the bottom of the buckle, push the slider of the buckle downward in the direction shown in the figure.

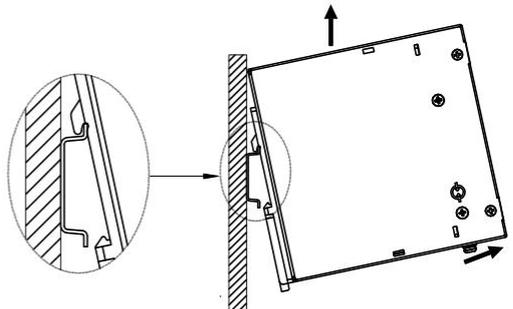

④Hold the bottom of the product and push it outwards, then lift the product up to take the product out of the DIN rail.

Wiring / Unwiring Steps ⑤-⑥

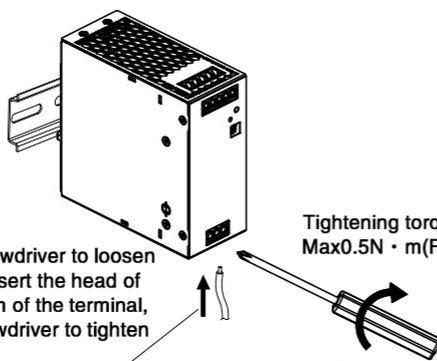

⑤Use the Phillips screwdriver to loosen the terminal screws, insert the head of the wire into the bottom of the terminal, and then turn the screwdriver to tighten the terminal screws.

Tightening torque:
Max0.5N · m(For reference);

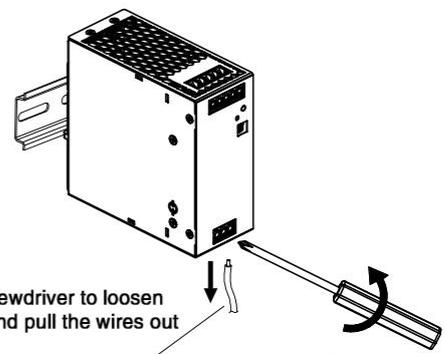

⑥Use the Phillips screwdriver to loosen the terminal screws and pull the wires out of the terminal holes.

Dimensions and Recommended Layout

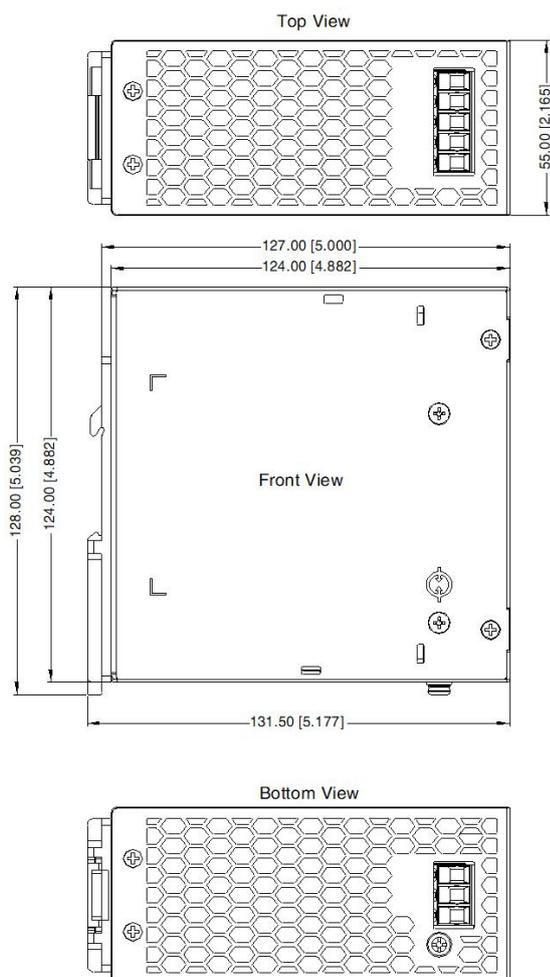

THIRD ANGLE PROJECTION

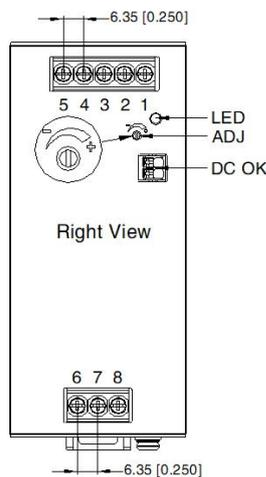

Pin-Out	
Pin	Mark
1	-Vo
2	-Vo
3	-Vo
4	+Vo
5	+Vo
6	AC(N)
7	AC(L)
8	

Note:
 Unit: mm[inch]
 LED: Output status indicator LED
 ADJ: Output adjustable resistor
 Wire range: Input: 16-10AWG(12-10AWG for Pin8)
 Output: 24V: 12-10AWG
 48V: 16-10AWG
 DC-OK: 24-16AWG
 Tightening torque: Max 0.5 N.m
 Mounting rail: TS35
 General tolerances: $\pm 1.00[\pm 0.039]$



WARNING Risk of electrical shock, fire, personal injury or death:

AVERTISSEMENT AVERTISSEMENT Risque de choc électrique, d'incendie, de blessures corporelles ou de décès :

1. Do not use the power supply without proper grounding (Protective Earth). Use the terminal on the input block for earth connection and not one of the screws on the housing;
N'utilisez pas l'alimentation électrique sans mise à la terre appropriée (Terre protectrice). Utilisez le terminal sur le bloc d'entrée pour la connexion terrestre et non pas une des vis sur le boîtier;
2. Turn power off before working on the device, protect against inadvertent re-powering;
Éteignez l'alimentation avant de travailler sur l'appareil, protégez-vous contre la réénergisation accidentelle;
3. Make sure that the wiring is correct by following all local and national codes;
Assurez-vous que le câblage est correct en suivant tous les codes locaux et nationaux;
4. Do not modify or repair the unit;
Ne modifiez pas ou ne réparez pas l'appareil;
5. Do not open the unit as high voltages are present inside;
Ne modifiez pas ou ne réparez pas l'appareil;
6. Use caution to prevent any foreign objects from entering the housing;
Faire preuve de prudence pour empêcher les objets étrangers d'entrer dans le logement;
7. Do not use in wet locations or in areas where moisture or condensation can be expected;
Faire preuve de prudence pour empêcher les objets étrangers d'entrer dans le logement;
8. Do not touch during power-on, and immediately after power-off, hot surfaces may cause burns; 
Ne touchez pas pendant l'alimentation et, immédiatement après l'alimentation, les surfaces chaudes peuvent causer des brûlures.
9. For ambient temperature $\leq 60^{\circ}\text{C}$, use $\geq 90^{\circ}\text{C}$ - copper wire only; for ambient temperature $>60^{\circ}\text{C}$ to 85°C , use $\geq 105^{\circ}\text{C}$ - copper wire only; use only wires with a minimum dielectric strength of 300V (input) and 60V (output);
Température ambiante $\leq 60^{\circ}\text{C}$, utiliser $\geq 90^{\circ}\text{C}$ - seulement fils de cuivre; Température ambiante $>60^{\circ}\text{C}$ et 85°C , utiliser $\geq 105^{\circ}\text{C}$ - seulement fils de cuivre; Uniquement pour l'utilisation de fils de cuivre d'une résistance d'isolation minimale de 300V (d'entrée) et 60V (de sortie).

Note:

1. For additional information on Product Packaging please refer to www.mornsun-power.com. Packaging bag number: 58220288;
2. Unless otherwise specified, parameters in this datasheet were measured under the conditions of $T_a=25^{\circ}\text{C}$, humidity $<75\%RH$ with nominal input voltage and rated output load;
3. The room temperature derating of $5^{\circ}\text{C}/1000\text{m}$ is needed for operating altitude greater than 2000m;
4. All index testing methods in this datasheet are based on our company corporate standards;
5. In order to improve the efficiency at high input voltage, there will be audible noise generated, but it does not affect product performance and reliability;
6. We can provide product customization service, please contact our technicians directly for specific information;
7. Products are related to laws and regulations: see "Features" and "EMC";
8. The out case needs to be connected to PE (\oplus) of system when the terminal equipment in operating;
9. The output voltage can be adjusted by the ADJ, clockwise to increase;
10. Our products shall be classified according to ISO14001 and related environmental laws and regulations, and shall be handled by qualified units.

Mornsun Guangzhou Science & Technology Co., Ltd.

Address: No. 5, Kehui St. 1, Kehui Address: No. 5, Kehui St. 1, Kehui Development Center, Science Ave., Guangzhou Science City, Huangpu District, Guangzhou, P. R. China

Tel: 86-20-38601850

Fax: 86-20-38601272

E-mail: info@mornsun.cn

www.mornsun-power.com

MORNSUN®

MORNSUN Guangzhou Science & Technology Co., Ltd.

2022.11.29-A/1

Page 10 of 10

MORNSUN Guangzhou Science & Technology Co., Ltd. reserves the copyright and right of final interpretation